

Fooke Endura 711 linear

form
cim

Verfahrenbereiche

X-Achse	-	2000 mm
Y-Achse	-	2800 mm
Z-Achse	-	1200 mm
A-Achse	-	± 110°
C-Achse	-	±275°

Spindel

Aufnahme	-	HSK63 A
Leistung	-	34 kW
Drehzahl	-	max. 24'000 min ⁻¹

Steuerung

Heidenhain	-	iTNC 530
------------	---	----------

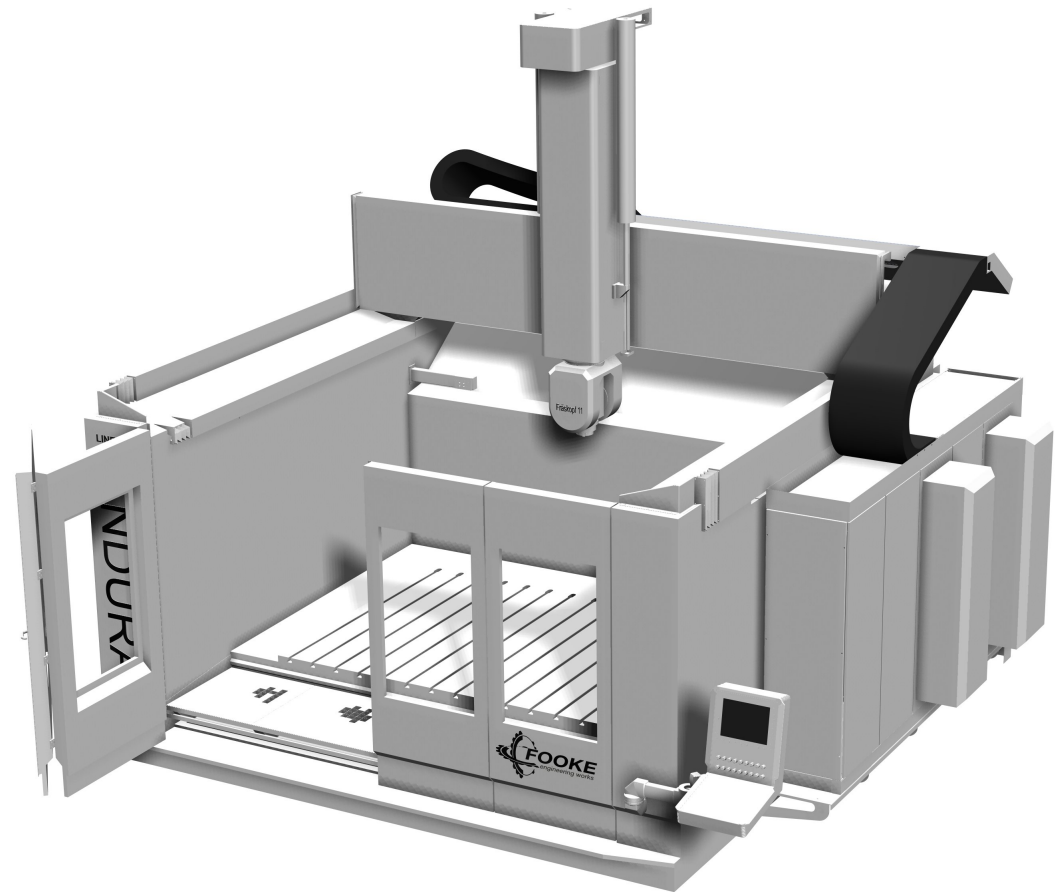

cimform ag
modell- und formenbau
ergeten 8 - CH-9225 st. pelagiberg
fon +41 (0) 71 434 66 44
fax +41 (0) 71 434 66 40
info@cimform.ch - www.cimform.ch